



HIWATT BALLAST
UV1192 /UV1807

Programmable
Electronic UV
Arc Lamp Ballast

INFORMATION IN THIS MANUAL IS SUBJECT TO CHANGE WITHOUT NOTICE

Uvitron International, Inc. • 171 Doty Circle • West Springfield, MA 01089
Phone (413) 731-7835 • Fax (413) 731-7767 • <http://www.uvitron.com>

CONTENTS

Section	Page
1.0 Introduction	3
2.0 Safety Considerations	4
2.1 – 2.2 Electrical & UV Safety	4
2.3 High Temperatures	5
2.4 Lamp Recycling	5
3.0 Theory of Operation	6
3.1 System Summary	6
3.2 Light Curing	6 - 7
3.3 System Information	7
3.4 Block Diagram	8
4.0 Controls and Indicators	9 - 10
5.0 Installation	11
5.1 General	11
5.2 Mounting	11
5.3 AC Input and Lamp Connectors Wiring	12
5.4 External Interface Wiring	13
5.5 Connector Pin-outs & Schematics	14 - 17
6.0 System Operation	18
6.1 Power On and System Start up	18 - 19
6.2 – 6.3 Standby & Run Modes	19 - 20
6.4 Intensity Control Ramp	20
6.5 Lamp Temperature Regulation	20 - 21
6.6 Shutdown	21
6.7 Lamp Hour Meter	21
6.8 Isolated Signal Supply Voltage	21 - 22
6.9 Lamp Over-temperature Switch	22
6.10 – 6.11 Ballast Alarm Descriptions & List	22 - 23
6.12 Alarm Temperature Limits and Timeouts	24
7.0 Troubleshooting	25 - 27
8.0 Replacement Parts & Accessories	28
9.0 Technical Specifications	29
9.2 - 9.3 Input Amps vs. Lamp Volts/Amps	30 – 33
9.4 Dimensions	34
10.0 Warranty Information	35

INTRODUCTION

1

1.1 Purpose Of Manual

The purpose of this manual is to provide installation, operation and troubleshooting instructions for the Uvitron International *HiWatt* electronic UV lamp ballast. It is important the manual be read carefully before any attempt is made to install and operate the equipment.

1.2 Purpose Of Equipment

The *HiWatt* system is an electronic ballast used to ignite and power UV and visible light producing arc lamps, for the rapid curing of photo-initiated inks, coatings, paints and adhesives. The *HiWatt* is user programmable for various lamp types (up to 10kW), and for various single or 3 phase AC input voltages for world-wide compatibility. The *HiWatt* can be paired with a range of standard length Uvitron Lamp irradiators, or with compatible customer lamps and housings. The unit is suitable for laboratory use or volume industrial production applications.

1.3 Unpacking

Visually inspect the shipping carton for physical damage. Damaged shipping cartons should be reported to the carrier. Carefully open the carton and remove the equipment, being careful not to lose or damage any separately packed parts.

Check all parts against the parts list. Any damaged or missing parts should be reported to the carrier and to your UVITRON representative.

All packing material and the shipping carton should be saved in case the unit has to be returned at some future time.

1.4 List Of Included Parts

1. One UV1192 or UV1807 *HiWatt* electronic UV arc lamp ballast.
2. One UV1557 lamp output 3 position pluggable terminal block.
3. One UV1558 AC power input 5 position pluggable terminal block.
4. One UV1826 *HiWatt Ballast* instruction manual.
5. One UV1809 *HiWatt* Interface Configuration Software CD ROM.
6. One (optional) UV1597 DB9 female control signal terminal block for field termination.
7. One (optional) UV1598 DB25 female control signal terminal block for field termination.
8. One (optional) UV1595 DB9 control signal terminal block gender changer, male / male.
9. One (optional) UV1596 DB25 control signal terminal block gender changer, male / male.

SAFETY CONSIDERATIONS

2

2.1 Electrical Safety

The HiWatt lamp ballast is designed to ignite and regulate power to high voltage and high current arc lamps. Accordingly, in order to avoid severe electrical shock, extreme caution must be taken to avoid coming in contact with live electrical connections associated with the ballast AC input and lamp output connections.

HIGH VOLTAGE



WARNING: Dangerous voltages may be present at the AC input and lamp output connectors and their associated wiring when an active electrical service is connected to the HiWatt ballast. The ballast also contains large capacitors for storing electrical energy. To prevent electrical shock, the electrical service must be disconnected at the facility electrical panel, and a 5 minute discharge period must elapse before any touching of the AC input or lamp connectors occurs.

Because of the complexity and high voltages present within the HiWatt ballast, no attempt should be made to remove the sheet metal covers, or to access or service the internal circuitry of the unit. The electrical system of this unit should be serviced by only UVITRON service personnel only.

2.2 UV Safety Warning



Ultraviolet radiation can cause severe burns to eyes and skin. Do not look at the light without protective eye shielding. (UVITRON UV/IR safety glasses Part No. UV0495, UV2231 or equivalent)

While thermal burns are felt immediately, UV burns are not felt for several hours. Short exposure to UV lamp radiation can cause severe burning of skin and eyes. UV burn of eyes affects the cornea and burning takes several days to heal. UV burn is identical to “Welders Burn” and will feel like sand in the eyes that cannot be washed out. The discomfort is temporary and has no lasting effects. Some effects of UV radiation can cause permanent damage to the eyes. *Never look directly at the operating arc lamp, with or without UV protective glasses.*

Exposure to UV radiation of only limited time will cause erythema (redness) on normal skin. Remember that a few seconds of exposure to direct radiation of the lamp can cause burns equal to a day in the sun. Such redness is temporary and will not produce blistering, or tanning, as only a small amount of radiation penetrates deeply. Extended exposure to UV radiation can lead to skin cancer. *When in the immediate vicinity of an operating UV emitting arc lamp, the use of UV/IR protective glasses, protective clothing and cotton gloves is required.*

UV arc lamps (especially UVB lamps) can also produce ozone that can be hazardous at sufficiently high exposure levels and durations. Arc lamp housings should be vented outdoors to insure safe ozone elimination. For more information, see the following OSHA website:

https://www.osha.gov/dts/chemicalsampling/data/CH_259300.html

SAFETY CONSIDERATIONS (CONTINUED)**2****2.3 High Temperatures**

Due to the high output power of this system, high temperatures may be present on the surfaces of the associated lamp, reflector, and lamp housing assembly (irradiator). *Extreme care should be taken to prevent touching any of these surfaces before allowing sufficient time for all temperatures to drop to safely back to room temperature after power has been removed.* Also, the lamp housing assembly should never be placed on or near any flammable surface while the lamp is on, or before its temperature has cooled back to room temperature. Never place the lamp housing or parts to be cured on a heat sensitive surface. Always cure parts on a metallic or non-flammable surface.

WARNING: Placing the lamp housing assembly on or near flammable surfaces while the lamp is on, or still hot could result in fire.

2.4 LAMP RECYCLING

UV curing arc lamps (sometimes referred to as bulbs) all contain some level of mercury, and should be disposed of responsibly in accordance to local, state and federal laws. Excellent guidelines for mercury lamp recycling can be obtained at the following National Electrical Manufacturers Association website: www.lamprecycle.org



Or call Uvitron customer service at (413) 731-7835 for more information.

THEORY OF OPERATION

3

3.1 System Summary

The Hi-Watt UV arc lamp ballast, is a dual processor controlled solid-state switching power supply, that consists of two power stages; a square wave AC output converter & igniter for powering a mercury vapor or halide arc lamp, and an auxiliary DC power supply for providing 3.3VDC and 24VDC for logic and cooling fans. The Hi-Watt is designed to be factory or customer software configurable (via PC serial port) to allow the unit to adapt to a wide range of lamp types, and utility power sources. This capability will allow the unit to power 1 or 2 lamps (in series) in the range of 1kW to 10kW, with lamp voltages of 200 to 850V, from single or 3 phase AC sources of 208/240/480V 60Hz – 200/230/380/415V 50Hz. This programmability makes the Hi-Watt a truly universal arc lamp ballast, that will allow it to be utilized as a single unit solution for powering many types of lamps from power sources worldwide.



The Hi-Watt has the ability to communicate to customer connected controllers or PCs via optically isolated digital logic signals, RS485 serial port or USB port. The logic signals include status lines for lamp ignited, lamp ready (warm-up-complete), and unit alarm, as well as control signals for lamp enable/disable, and lamp dimming (via PWM control, pulse frequency or 0 to 10V). Lamp cooling blower control is also provided, with blower On/Off signal, air temperature/flow regulation and lamp temperature monitoring. The unit can optionally power 24V DC cooling fans, and vary the fan speeds either open loop or based on lamp temperature. Units can also be networked to provide customer interface to multiple Hi-Watt slave units from the serial ports. This option will allow interface to multiple lamp systems cascaded on a single high speed product line, which can still be controlled and monitored as a single system with much higher power capability.

Refer to the following pages for system specifications, interface information and unit dimensions.

3.2 Light Curing

Ultraviolet (UV) Light exists around us as one of nature's phenomenon, an example of which is ultraviolet rays produced by natural sunlight. Ultraviolet light can also be artificially produced by an electrical arc, enclosed in special glass to allow its passage (a UV arc lamp).

Reactive materials called photoinitiators are added to resins for adhesive bonding, coating, sealing, and printing. Ultraviolet light will cure these adhesives by causing the liquid resin to polymerize, thus becoming a solid. This could be compared to two part epoxies, which when mixed in the proper proportions turn from a liquid to a solid. Light curing resins on the other

THEORY OF OPERATION (CONTINUED)

3

hand, are single component products ready to use as received without measuring or mixing, and cure on-demand when exposed to UV light.

The photoinitiators added to the adhesive chemistry react to a specific range of light wavelengths, and the speed of the reaction is governed primarily by the intensity (or irradiance) of the light source for those wavelengths and by the chemistry of the adhesive. Approximate adhesive cure time can be calculated as follows:

$$\text{Curing Time [seconds]} = \text{Light Energy [Joules/cm}^2\text{]} / \text{Light Intensity [Watts/cm}^2\text{]}$$

Adhesive manufacturers typically specify the energy required for curing, or the required intensity and time duration. For some adhesive types, the relationship between the speed of curing and lamp intensity is not linear (doubling the intensity does not offer half the cure time). The fastest and most complete reaction may occur at high peak intensity for a relatively short period of time. This may be a more effective type of curing as compared to a similar (or even a higher) dose of UV light, which is spread over longer period of time.

NOTE: Various types of inks, coatings and adhesives from different manufacturers have different levels of reactivity which will require adjusting of exposure times for proper curing. Consult with the adhesive manufacturer for appropriate cure times for each type of material.

3.3 System Information

The *HiWatt* is a multistage programmable electronic ballast that is capable of operating from various types of 3 phase or single phase power sources, and is also adaptable to various lamp sizes and types. The HiWatt also has an isolated auxiliary power converter for supplying customer 3.3V and 24V loads.

The HiWatt features a RS485 serial port for applications requiring remote control of curing operations. The unit also includes a USB port which is primarily intended for initial setup and configuration of the system parameters. Refer to the HiWatt Ballast Interface Software Instructions enclosed with the included configuration programming CD for more information.

NOTE: For communication with a single ballast, either USB or RS485 may be used. However, due to its better noise immunity and longer maximum cable lengths, it is recommended to use the RS485 port for high powered operations with an operating lamp.

If multiple ballasts are required, RS485 can also be used to control up to 8 units per network. If remote control via RS485 from a customer programmed PLC is desired, refer to the HiWatt Serial Communication Protocol Description (available from Uvitron customer service) for specific protocol and Modbus register information.

THEORY OF OPERATION (CONTINUED)

Refer to the system block diagram below for an overview of the HiWatt ballast architecture.

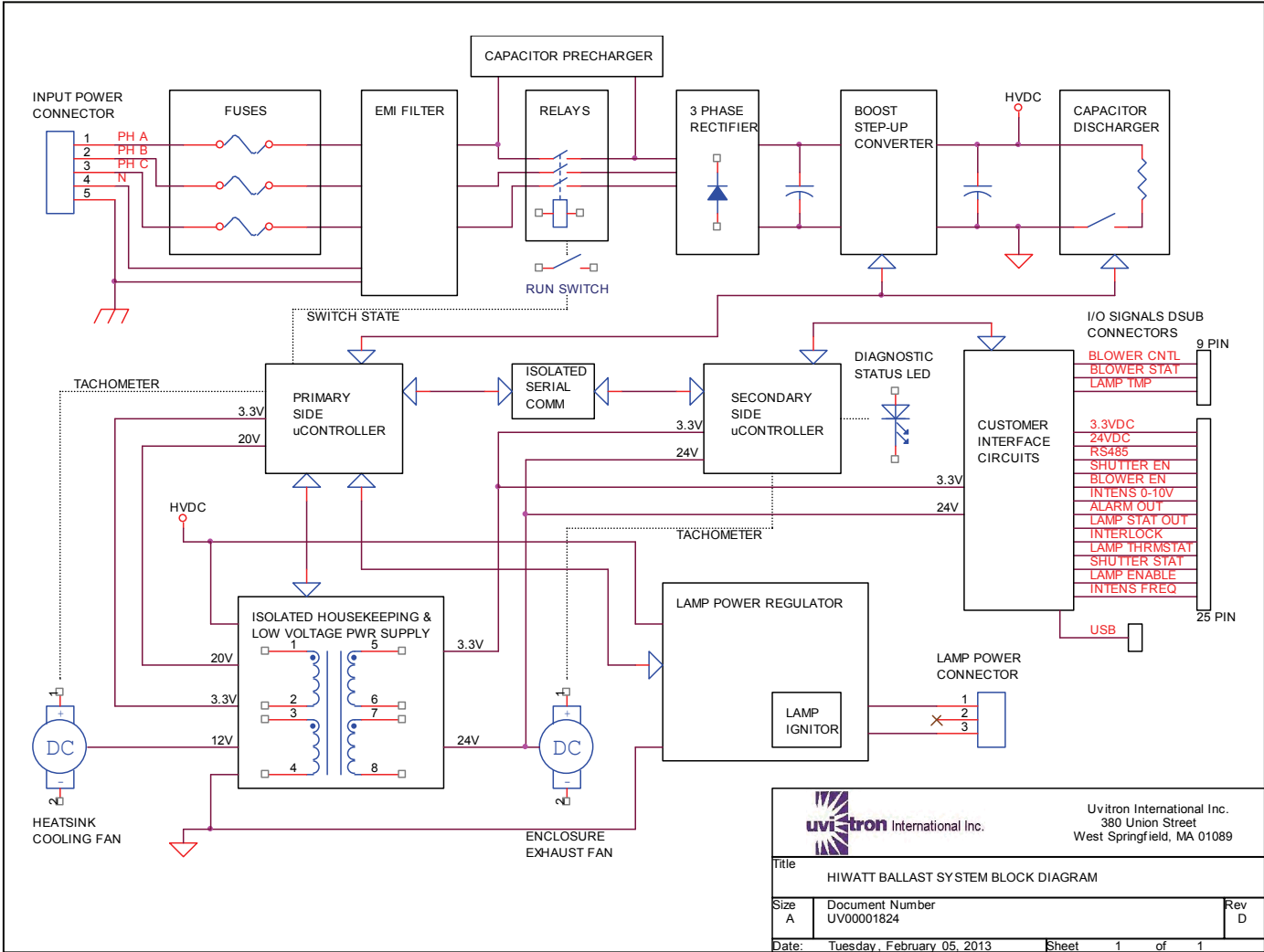

Fig. 1, System Block Diagram

CONTROLS AND INDICATORS

4

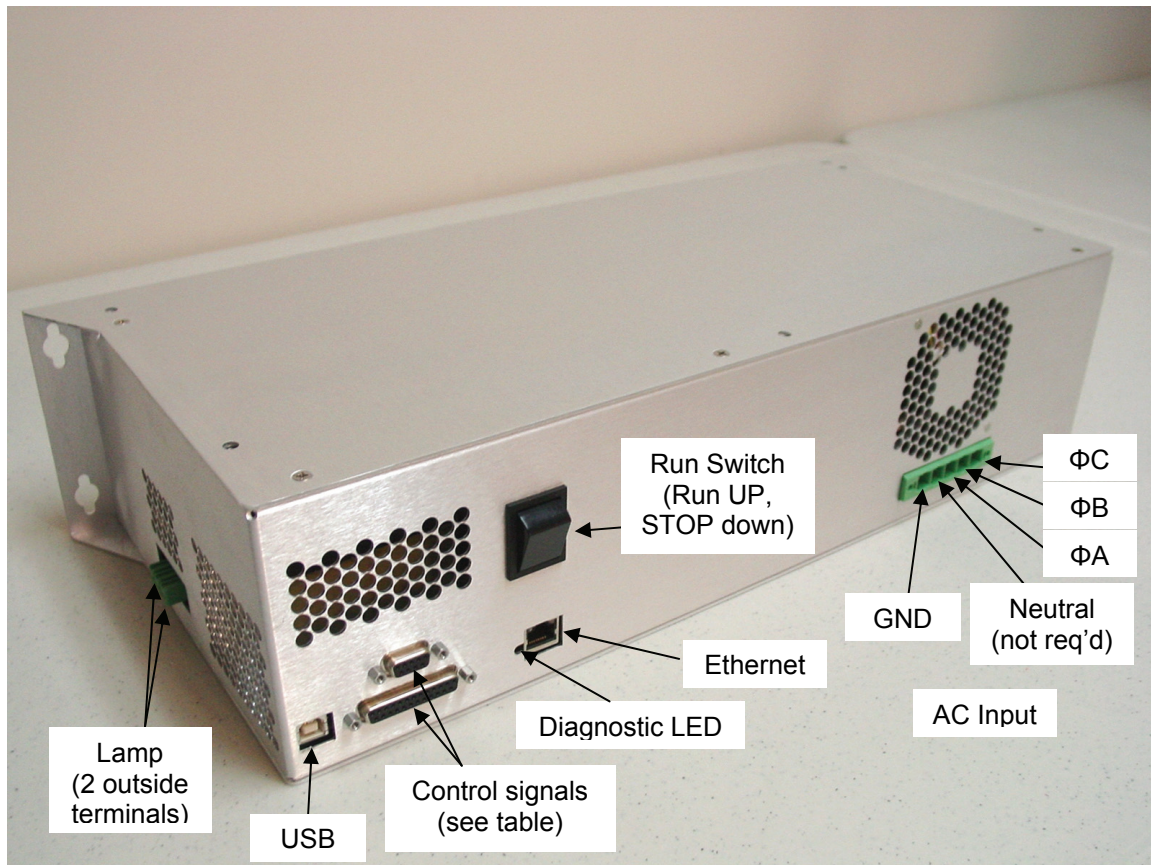

Fig. 2, Location of controls and indicators

CONTROLS AND INDICATORS (CONTINUED)**4**

Item	Description
1. Lamp Connector	<p>The lamp output connector is a pluggable 3 position terminal block, wire gauge range 10 to 24 AWG.</p> <p>WARNING: High voltage is present at this connector during operation. Disconnect AC Input power and wait 5 minutes for internal capacitors to discharge before touching.</p>
2. USB Connector	<p>The USB connector is used in conjunction with the HiWatt Interface Configuration Software for programming and storing the unit's input voltage, lamp and operating parameters. The internal microcontroller can be powered via the PC USB port during programming (no ballast high voltage input required).</p>
3. Control Signals DSUB Connectors (9 & 25 pin)	<p>These two connectors are used to interface digital, analog and RS485 serial I/O signals to the ballast for system monitoring and remote control. See section 5.5 for signal descriptions.</p>
4. Diagnostic LED Status Indicator	<p>This recessed LED provides the user with a quick way to check the operating status of the ballast. During normal operation, the LED will be illuminated green, with an occasional blink to indicate the onboard processor is operating. If an alarm condition occurs, the LED will turn red, and will flash a number of times to indicate the cause of the alarm. To decode the particular alarm condition, refer to the LED Flash Count in the Alarms List table of section 6.11.</p>
5. Ethernet Connector (future upgrade, not yet supported).	<p>This connector is for communication with industrial networks via Ethernet IP protocol. Ethernet is not yet supported.</p>
6. Run/Stop Switch	<p>This switch can be used to connect/disconnect input power to the ballast via an internal software controlled 3 phase relay.</p> <p>WARNING: This switch does not completely remove all power from the ballast. Power must be disconnected at its source before performing any maintenance on or near the lamp ballast.</p>
7. AC Input Connector	<p>The AC Input connector is a pluggable 5 position terminal block, wire gauge range 8 to 18 AWG. This should be connected to a AC power source as is appropriate for the selected lamp.</p> <p>WARNING: High voltage is present at this connector when AC input power is applied. Disconnect AC Input power and wait 5 minutes for internal capacitors to discharge before touching.</p>

INSTALLATION**5****5.1 General**

The *HiWatt* electronic UV arc lamp ballast is housed in a rugged sheet metal enclosure that is intended to be panel mounted in a vented, electrically safe protective enclosure. The HiWatt AC input and lamp output connectors have dangerous high voltages present at their terminals, and therefore an electrically grounded enclosure should be used to limit unit access to only qualified service personnel.

The HiWatt contains internal cooling fans to evacuate heat from its housing. Allow a 4-inch clearance around the ballast's air inlet and outlet venting holes for unrestricted airflow. When placing the HiWatt unit into a protective enclosure, a minimum of 50 CFM of forced air cooling (per unit) should be provided to exhaust hot air, to avoid excessive temperature rise which could damage the ballast. Since it is an air-cooled unit, dust or airborne particles can clog the internal cooling passages of the HiWatt and cause overheating. Therefore, it is recommended to use a cleanable type air filter over the protective enclosure air inlet to prevent contaminants from entering the HiWatt which could reduce cooling efficiency or otherwise damage the unit.



Fig. 3, HiWatt ballast assembly

5.2 Mounting

The HiWatt chassis features two integrated flanges with slotted mounting holes (see figs. 4 & 9). These holes can be used when it is desirable to attach the unit onto a panel with screws from the front side. The slotted holes allow the unit to be placed on/off the panel by only loosening (but not removing) the mounting screws. The unit also can be optionally mounted using either of the two sets of captive blind threaded fasteners located on two different sides of the HiWatt chassis. These can be used for cases when it is

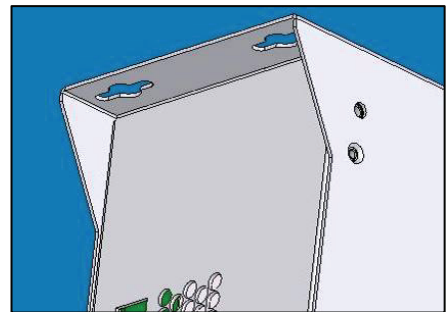

Fig. 4, chassis mounting flange

desirable to screw the unit in place from the opposite side of an enclosure panel. Refer to the HiWatt dimensional drawing in fig. 9 for the location, size and maximum depth of these captive fasteners. It is recommended that the HiWatt be mounted vertically with the exhaust fan port toward the top. This will insure that cool air at the bottom of the protective enclosure or cabinet will enter into the HiWatt air inlets, and the hotter rising air will exit from the fan exhaust port and be vented directly from the cabinet. Cabinet air inlet and outlets should be placed accordingly.

INSTALLATION (CONTINUED)

5.3 AC Input and Lamp Connectors Wiring

Wiring of the HiWatt ballast AC input connector (for either 3 phase or single phase applications) and the lamp output connector is shown below:

HIGH VOLTAGE



WARNING: Dangerous voltages may be present at the AC input and lamp output connectors when an active electrical service is connected to the HiWatt ballast. To prevent electrical shock, the electrical service must be disconnected at the facility electrical panel, and a 5 minute discharge period must elapse before any touching of the AC input or lamp connectors occurs.

3 Phase AC Input Wiring

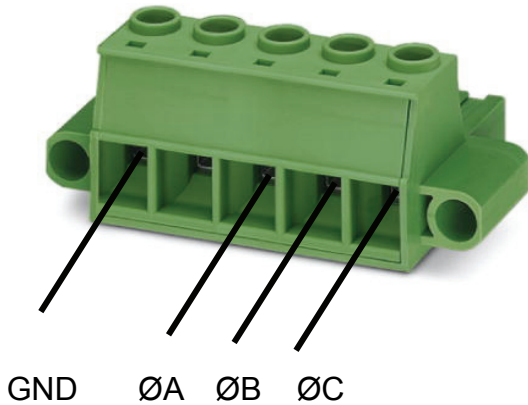

Single Phase AC Input Wiring

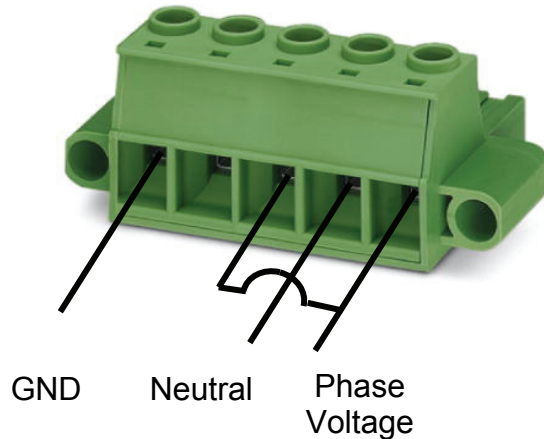

Note that the single phase wiring has two terminals connected to the AC phase voltage. This connection is required to prevent AC input inrush current during pre-charging of ballast DC bus capacitors. Wire gauge should be selected according to the expected AC input current for a given lamp type, AC input voltage and number of phases. Refer to the AC input current charts in the Specifications section for more information.

Connect the arc lamp wires to the two outside terminals of the 3 position connector as shown in the photo to the right. Note that the center terminal is not used, and is left open to increase high voltage spacing between conductors. Due to the 5 to 10kV lamp ignition voltage, it is recommended to use silicone high voltage insulated wiring for connection of the lamp to the ballast. Also, in order to reduce radiated EMI from the ballast, it is best to minimize the loop area between the two lamp wires (twisting the pair if possible).

Lamp Output Connector Wiring

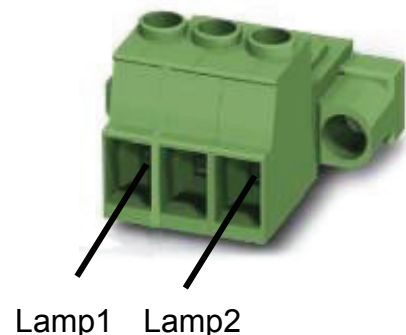

INSTALLATION (CONTINUED)**5****5.4 External Interface Wiring**

External monitoring and control of the HiWatt is possible by wiring to the unit's 9 and 25 pin control signal connectors. Refer to the following Power & Signal Connector Pin Assignments table for a listing and description of available interface connector signals. Also, see figures 5 through 7 below for wiring schematic examples for typical configurations.

Note: Due to the high power input and output of the HiWatt ballast, proper shielding, wire twisting and routing of sensitive control signals is required to provide electrical noise immunity in interface control cabling. High current input and output power wiring should be routed away from control signals, and loop area between high current conductors should be minimized by bundling or twisting to minimize electro-magnetic interference (EMI) radiation. Control signal cables should be shielded, and analog signal pairs should be twisted as well (see shielding symbols in example schematics below).

For installations requiring long interface cables lengths, full isolation of input/output control signals using the ballasts internal opto-couplers, external control relays and external 24V isolated power supply is recommended (see example in fig. 7 below).

5.5 Power & Signal Connector Pin Assignments

Ballast Connectors	Pin #	Pin Name	Description
J6, Input Power Connector	1	Earth Ground	This connector is a pluggable terminal block that is used to connect the 1 or 3 phase AC input power wiring to the ballast.
	2	Neutral	
	3	Phase A	
	4	Phase B	
	5	Phase C	
J1, Lamp Output Connector	1	Lamp AC1	This connector is a pluggable terminal block that is used to connect the arc lamp to the ballast.
	2	No Connection	
	3	Lamp AC2	
J9B, Lamp Blower & Temp Sensor Signals Connector	1	Airflow Damper COM/VFD PWM Out	This is a 9 pin DSUB connector that is used to interface to lamp blower temperature control signals with either an electronically controlled air flow damper or variable frequency drive (VFD). Connections for a thermistor for monitoring and regulating lamp temperature are also provided.
	2	Airflow Damper CLOSE	
	3	Blower Contactor/VFD Status In	
	4	Lamp Temp Thermistor +	
	5	Signal Return	
	6	Airflow Damper OPEN/+24V Out	
	7	/Shutter Enable Out (Optional)	
	8	/VFD Enable Out	
	9	Lamp Temp Thermistor Return	
J9, Auxiliary Power Output, Signal Interface and RS485 Connector	1	Customer +3.3V Out	This is a 25 pin DSUB connector that is used to supply +3.3V (0.5A) and +24V (1.0A) to customer loads. The connector also carries command and status signals for control and monitoring of the ballast by a customer PLC or other controller.
	2	Customer +24V Out	
	3	Customer +24V Return	
	4	Customer +3.3V Return	
	5	RS485_B (Serial Port)	
	6	/Blower Contactor Enable Out	
	7	Lamp Dimming 0-10V In	
	8	Isolated Signal Supply+ (Optos)	
	9	Alarm Out*	
	10	/Lamp Ready Out*	
	11	/System Interlock In	Lamp dimming can be controlled via a 0 to 10VDC command applied between pins 7 and 20. Optionally, the Lamp Dimming Digital input can be used to vary the lamp power from 20 to 100% by varying either the duty cycle (0 to 100%), or the frequency (10 to 2000 Hz) of the applied signal. Selection of these 3 intensity command modes is software programmable via the HiWatt Interface Configuration program.
	12	/Shutter Open In (Position Feedbk)	
	13	Lamp Dimming Digital In, PWM/Freq	
	14	Customer +24V Out	
	15	Customer +24V Return	
	16	Customer +24V Return	
	17	RS485_A (Serial Port)	
	18	/Shutter Enable Output	
	19	/Lamp Ready High Current Out	
	20	Lamp Dimming 0-10V Return	
	21	Isolated Signal Return (Optos)	
	22	/Lamp Ignited Out*	
	23	Spare Isolated Out*	
	24	/Lamp Overtemp Switch In	
	25	/Lamp Enable In	

* Low current opto-isolated outputs, add Altech RSM-24CU relay or similar for higher current.

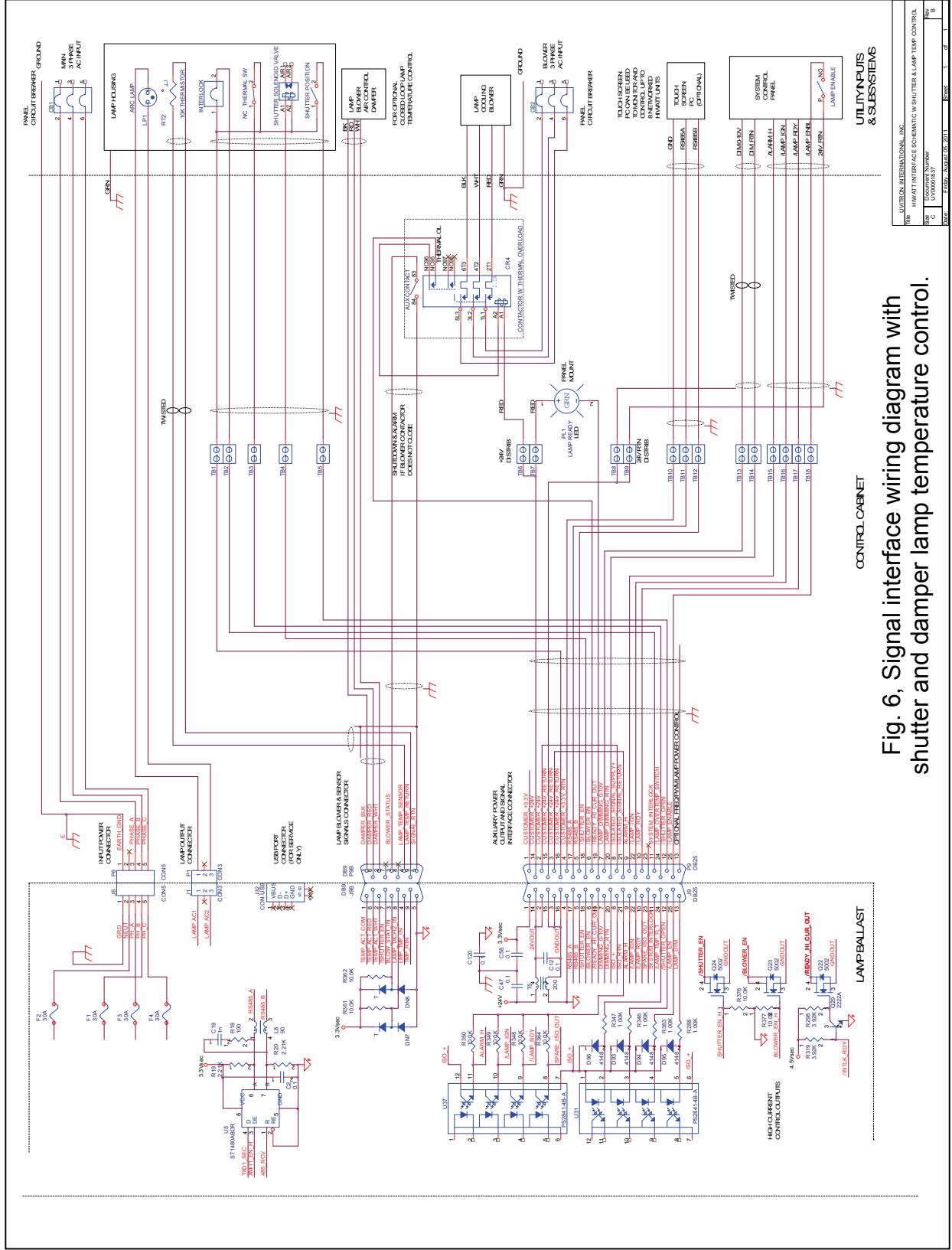

Fig. 6, Signal interface wiring diagram with shutter and damper lamp temperature control.

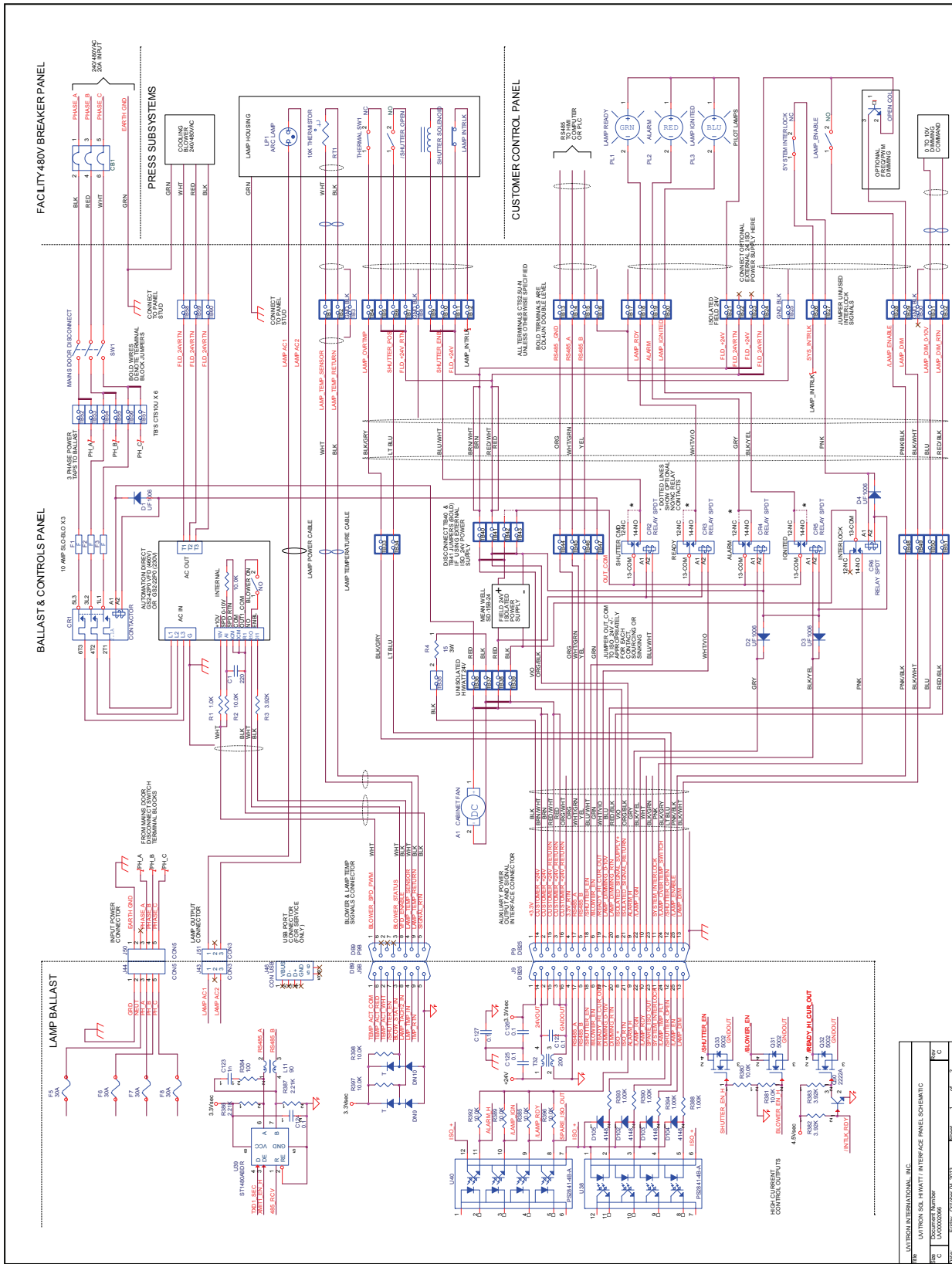

Fig. 7, Fully isolated interface wiring diagram with shutter and VFD lamp temperature control.

SYSTEM OPERATION

6

The HiWatt ballast is relatively easy to operate. Ballasts are typically factory pre-programmed for customer AC input voltage, lamp type and other system parameters specified at time of order. However, each unit ships with a CD containing the HiWatt Ballast Interface program that can be used for programming configuration settings. This program can also be used for system monitor and control during curing operations. Refer to the HiWatt Ballast Interface Software Instructions enclosed with the installation CD for more information. If remote control of the ballast from a PLC, PC or other device using custom Modbus serial communications software is desired, contact Uvitron Customer Support to receive a copy of the HiWatt Serial Communication Protocol Description.

Once input and output wiring has been completed and verified (refer to Installation in section 5), and optional configuration software has been installed, the system is ready to power on.

6.1 Power On and System Start Up

For safety, first verify that the HiWatt ballast AC input power is turned OFF at the appropriate breaker in the facility breaker panel. To allow the ballast to enable its input power relays and activate the unit once power is applied, turn on the ballast's Run Switch (refer to figure 2 for the Run Switch location and setting position). Before proceeding, verify that the HiWatt ballast is safely enclosed, locked and appropriately labeled to prevent any personnel from inadvertently touching the ballast input or output high voltage connectors.

HIGH VOLTAGE



WARNING: Dangerous voltages may be present at the AC input and lamp output connectors and their associated wiring when an active electrical service is connected to the HiWatt ballast. The ballast also contains large capacitors for storing electrical energy. To prevent electrical shock, the electrical service must be disconnected at the facility electrical panel, and a 5 minute discharge period must elapse before any touching of the AC input or lamp connectors occurs.

Once the ballast safety enclosure is verified to be closed and locked, apply power to the ballast AC input connector by turning on the appropriate breaker in the facility breaker panel. If the HiWatt is mounted in a cabinet with its own power disconnect switch or circuit breaker, then turn on this control accordingly. The HiWatt pre-charger circuit will gradually charge the unit's input capacitors, preventing any high AC inrush current surge. During this pre-charging phase, the HiWatt's Diagnostic LED will flash periodically as the internal primary side microcontroller tests to determine if the capacitors have reached the expected voltage level for the programmed AC input voltage setting. Once the pre-charge is complete, the HiWatt will automatically close its internal relays, which will apply AC input power to the unit's internal circuitry. The ballast's fans will turn on, and the Diagnostic LED will light solid green, with an occasional blink to indicate continuous processor activity.

At this time, the HiWatt's internal Boost Step-up Converter and House-keeping Power Supply stages are active. However, by default the Lamp Power Regulator will not turn on the lamp until

SYSTEM OPERATION (CONTINUED)**6**

the /Lamp Enable signal (pin 25 of the 25 pin DSUB signal connector) is pulled low. Once the /Lamp Enable signal is pulled low, ignition pulses will be delivered by the Lamp Power Regulator stage to activate the lamp, and the /VFD & /Blower Contactor Enable outputs (pin 8 of the 9 pin and pin 6 of the 25 pin DSUB signal connectors respectively) will go low to activate the lamp cooling blower. After the blower is activated, the unit expects to receive a contact closure between the Blower Status Input and Return (pins 3 and 5 of the 9 pin DSUB connector) which indicates that the VFD has turned on or that the blower contactor has closed. If the signal is open, the ballast assumes that there is no lamp cooling, and the unit will alarm and shut down. If this arrangement is not preferred, a jumper can be connected between the two Blower Status pins.

The HiWatt's secondary side microcontroller will monitor the state of the /System Interlock signal (pin 11 of the 25 pin DSUB signal connector) to verify that all required shields and guards are in their required positions. If the interlock signal is not pulled low to 24V return, the lamp will not turn on (or if on, the lamp will turn off), and an appropriate alarm condition will be signaled.

Once the lamp ignites, the unit will assert the /Lamp Ignited output signal low (pin 22 of the 25 pin DSUB signal connector). Constant current will then be applied to the arc lamp (as programmed in the ballast's internal Lamp Current Limit register), and the lamp's voltage will begin to rise as the lamp warms up.

6.2 Standby Mode

Once the Lamp voltage reaches a minimum level of 90% of the value pre-programmed into the ballast's Rated Lamp Voltage register, the HiWatt will assert its /Lamp Ready and /Lamp Ready High Current Out signals (at pins 10 and pin 19 respectively of the 25 pin DSUB signal connector). The ballast will then reduce its output power to the lamp to a level as pre-programmed in the unit's Standby Power Level register. The HiWatt will remain in the low power standby mode until lamp intensity is commanded high via the Lamp Dimming 0-10V analog inputs, or the Lamp Dimming Digital input (signals between pins 7 and 20 or at pin 13 respectively of the 25 pin DSUB signal connector).

The intensity dimming control mode can be selected via the Intensity Input Select register using the supplied configuration program software. Note that the digital dimming input can be either frequency or pulse width modulation (PWM) controlled. The control range in the frequency mode is 10 to 2000 Hz. This range is compatible with speed wheels or encoders which can be used to control lamp power based on web or belt speed (1 Hz = 1 foot per minute or similar). For PWM control, the control range is 0 to 100%, at a nominal PWM frequency of 500 Hz.

6.3 Run Mode

As the appropriate intensity input level is increased beyond the level programmed in the internal Shutter Open register, the ballast will enter Run Mode. The /Shutter Enable Output (pin 18 of

SYSTEM OPERATION (CONTINUED)**6**

the 25 pin DSUB signal connector and pin 7 of the 9 pin DSUB signal connector) will then assert low to command the lamp shutter open (assuming an optional lamp shutter is present). The HiWatt's secondary side micro controller will then monitor the state of the /Shutter Open Input (pin 12 of the 25 pin DSUB signal connector) connected to a shutter position switch to verify that the shutter opens as expected. Note that if no shutter or shutter position switch is used in the current system configuration, then the /Shutter Enable Output should be wired directly to the /Shutter Open Input signal to prevent a false alarm condition from being detected and signaled.

6.4 Intensity Control Ramp

While in Run Mode, the ballast will regulate constant lamp power at a level proportional to the intensity command input. The scaling of the analog and digital intensity command inputs is programmed via the HiWatt's internal intensity control registers as shown in the diagram of figure 8 below. These registers allow for programming a customized slope of intensity versus command input, which allows system service personnel to tailor the power delivered to the lamp as the command input is varied. If variable output power is not required, then the lamp standby power level can be set equal to the rated lamp power using the configuration program software, and the unit output will be set to full power any time the lamp is enabled.

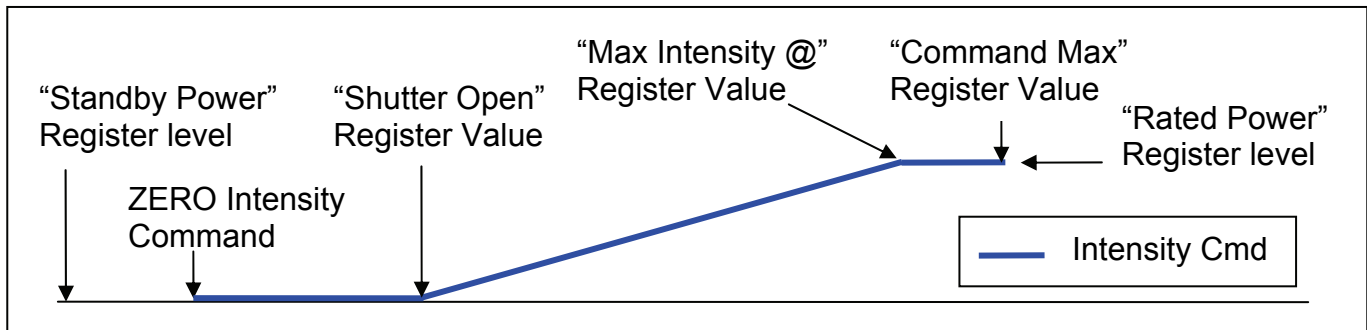

Fig. 8, Intensity vs. Command (as set by internal control registers)

Note that the /Shutter Enable Output will remain asserted low to keep the shutter open until the intensity input level is decreased below the level programmed in the internal Shutter Close register, at which time the shutter will close.

6.5 Lamp Temperature Regulation

Arc lamps are relatively temperature sensitive, and must operate in a specified range in order to insure proper performance and maximize life. For applications where large variations in lamp power are required, the HiWatt can be optionally configured to monitor and regulate lamp air or heatsink temperature, preventing over-cooling or over-heating of the lamp. In order to achieve this, a 10K ohm NTC thermistor should be connected between the Lamp Temp Thermistor and

SYSTEM OPERATION (CONTINUED)**6**

Lamp Temp Thermistor Return signals (pins 4 and 9 respectively of the 9 pin DSUB signal connector) to measure the lamp cooling air or heatsink temperature. This temperature reading can then be used to regulate appropriate airflow to the lamp using either a motorized airflow duct damper, or a variable frequency drive (VFD) which will adjust the blower motor speed. Refer to schematics of figures 6 and 7 for damper and VFD wiring configuration examples.

The HiWatt ballast has an internal PI lamp temperature regulator, whose proportional gain, integral gain and setpoint temperature control parameters are adjustable via the configuration program software for tailoring response to the particular system. There is also a programmable Cooldown parameter which controls how long the cooling blower will run when the lamp is turned off by either the operator or by a system fault. When the lamp turns off, the temperature controller will increase airflow to maximum to provide rapid cooldown, limiting lamp temperature over-shoot, and minimizing required subsequent restart time of a hot lamp. When an airflow damper is used, the cooldown will be specified as the number of seconds to operate at maximum flow before turning off the blower. When a VFD is used, the Cooldown parameter will specify the reduced temperature at which the blower will turn off (up to a maximum of 180 seconds of cooldown time). Note that if the lamp temperature at turn off is less than the VFD cooldown temp setting, the blower will run at maximum speed for a minimum of 30 seconds to facilitate rapid subsequent restart of a hotter than normal lamp.

6.6 Shut Down

To shut down the light cure system, reduce the lamp intensity command to minimum, turn off the lamp enable input (if applicable), wait for lamp cooldown (specified in the Cooldown Time/Temp register) to complete, and remove AC input power at the source by turning off the cabinet disconnect switch and/or the circuit breaker at the facility panel. Next, shut off the HiWatt's Run Switch.

6.7 Lamp Hour Meter

The HiWatt tracks the age of the arc lamp for replacement scheduling. When using the configuration program software, the current lamp hours are displayed in the Lamp Status section of the main screen. When a new lamp is installed, the hour meter can be reset in the System Service Settings screen. If a new lamp is installed, then a value of zero should be entered for Lamp Hours. If a previously used lamp is installed, then the current age of the used replacement lamp should be entered. Refer to the HiWatt Ballast Interface Software Instructions enclosed with the installation CD and to the program's online help for more information.

6.8 Isolated Signal Supply Voltage

The ballast has several opto-isolated digital input and output signals. If isolation is not required, then the units internally generated 24V output can be used to bias the internal opto-couplers by placing jumpers on the 25 pin DSUB connector from the 24V output (pin 2 or 14) to Isolated

SYSTEM OPERATION (CONTINUED)**6**

Signal Supply+ (pin 8), and from the 24V return (pins 3, 15 or 16) to Isolated Signal Return (pin 21). Otherwise the customer will need to supply voltage from an external isolated power supply to provide fully isolated signals. See an example of the described wiring connections in the schematics of figure 5 through 7 above.

6.9 Lamp Over-temperature Switch

The HiWatt has the ability to monitor an over-temperature thermal switch in the lamp housing which will shut down the lamp if the temperature is excessive. This feature can be used as a fail-safe for conditions such as a cooling blower fault or cooling air restriction. The unit expects to receive a contact closure between /Lamp Overtemp Switch and 24V return (pins 24 and pins 3, 15 or 16 of the 25 pin DSUB connector) indicating that the lamp temperature is below the maximum limit. If the signal opens, the ballast assumes that the lamp temperature is excessive, and the unit alarms and shuts down. If this arrangement is not preferred, a jumper may be connected between the /Lamp Overtemp Switch feedback signal at pin 24 and the 24V return.

6.10 HiWatt Ballast Alarms

The HiWatt, ballast has two internal microcontrollers (one on the high voltage primary side of the internal circuits, and another on the isolated secondary low voltage side) that control and monitor the state of the lamp system and peripheral equipment. If any exception condition is detected by these processors, an alarm will be signaled via the USB or RS485 serial port alarm fault code register, and the unit's Diagnostic LED will flash a number of times to indicate the appropriate alarm code (as described in the alarms list table below).

Note that if the LED flashes a code with a green color, this indicates an informational event only. If the LED alternately flashes green then red, then this indicates a warning condition. If the LED flashes a red code, then this indicates a fault condition has occurred. In this fault case, the lamp output will be turned off, lamp cooldown will begin, and the HiWatt will assert the Alarm output signal high (pin 9 of the 25 pin DSUB signal connector).

6.11 HiWatt Ballast Alarms List

Revision 3.06, 5/04/11

Alarm Name	Alarm Description	Fault Code	LED Flash Count	LED Flash Color	Alarm Type	Alarm Bit & Register
ALM_STAT_NORMAL	Normal status, no active alarm	0	1	GRN flicker	None	OFF
ALM_COMM_ERROR	Ballast communication error detected	1	1	GRN	Event	OFF
ALM_SEC_MST_DSBLD	Ballast Secondary to Primary Modbus comm disabled	2	2	GRN	Event	OFF
ALM_BAL_PRI_UC_TEMP_WRN	Ballast primary uC over-temperature warning	3	1	GRN/RED	Warning	OFF
ALM_BAL_SEC_UC_TEMP_WRN	Ballast secondary uC over-temperature warning	4	2	GRN/RED	Warning	OFF
ALM_BAL_BOARD_TEMP_WRN	Ballast board sensor over-temperature warning	5	3	GRN/RED	Warning	OFF
ALM_EXHAUST_AIR_TEMP_WRN	Lamp exhaust air over-temperature warning	6	4	GRN/RED	Warning	OFF
ALM_COMM_TIMEOUT_SEC_FLT	No comm HMI to sec, shut lamp and report	7	1	RED	Fault	ON
ALM_COMM_TIMEOUT_PRI_FLT	No comm. sec to pri, shut lamp and report	8	2	RED	Fault	ON
ALM_LAMP_EXTINGUISHED	Lamp extinguished after warm-up complete	9	3	RED	Fault	ON
ALM_LAMP_WARMUP_TIMEOUT	Too long for lamp warm-up	10	4	RED	Fault	ON
ALM_IGNITION_FAULT	No ignition after 3 minutes	11	5	RED	Fault	ON
ALM_BAL_PRI_UC_TEMP_FLT	Ballast primary uC over-temperature fault	12	6	RED	Fault	ON
ALM_BAL_SEC_UC_TEMP_FLT	Ballast secondary uC over-temperature fault	13	7	RED	Fault	ON
ALM_BAL_BOARD_TEMP_FLT	Ballast board sensor over-temperature fault	14	8	RED	Fault	ON
ALM_EXHAUST_AIR_TEMP_FLT	Lamp exhaust air over-temperature fault	15	9	RED	Fault	ON
ALM_BAL_PRI_FAN_FLT	Ballast primary heatsink fan speed fault	16	10	RED	Fault	ON
ALM_BAL_SEC_FAN_FLT	Ballast secondary enclosure fan speed fault	17	11	RED	Fault	ON
ALM_CASS_UNLOCKED	Lamp cassette not locked or not installed	18	12	RED	Fault	ON
ALM_CASS_TEMP_FLT	Lamp cassette over-temp switch activated	19	13	RED	Fault	ON
ALM_SHUTTER_POS_FLT	Shutter position does not match command	20	14	RED	Fault	ON
ALM_BLOWER_FAULT	Loss of "blower ON" feedback signal	21	15	RED	Fault	ON
ALM_PRESS_FLOW_FAULT	Pressure or flow fault switch activated	22	16	RED	Fault	ON

SYSTEM OPERATION (CONTINUED)**6****6.12 Alarm Temperature Limits and Timeouts****Alarm Temperature Threshold Limits** (values in degrees C)

Temperature Threshold Type	Temp [Deg. C]	Description
UC_DIE_TEMP_WRN_THRSH	75	Primary & Secondary side Micro Controller die temp warning threshold
UC_DIE_TEMP_FLT_THRSH	85	Primary & Secondary side Micro Controller die temp fault threshold
BAL_BRD_TEMP_WRN_THRSH	65	Ballast board temp sensor warning threshold
BAL_BRD_TEMP_FLT_THRSH	75	Ballast board temp sensor fault threshold
LAMP_EXH_TEMP_WRN_THRSH	10	Lamp exhaust temp warning thresh=SetPoint+10C
LAMP_EXH_TEMP_FLT_THRSH	20	Lamp exhaust temp fault thresh=SetPoint+20C

Alarm timeouts (Times in seconds)

Alarm Timeout Type	Time [Secs.]	Description
CASS_LOCK_TIMEOUT	0.3	300mSec filter on cassette locked/interlock signal
LAMP_THRMSTAT_TIMEOUT	0.3	300mSec filter on lamp thermal switch signal
SHUTTER_POS_TIMEOUT	2	2 sec timeout waiting for shutter to actuate
BLOWER_FB_TIMEOUT	2	2 sec timeout waiting for blower feedback signal
PRESS_FLOW_TIMEOUT	2	2 sec timeout waiting for pressure/flow fault signal
LAMP_WARMUP_TIMEOUT	180	180 sec timeout waiting for Lamp Ready signal

TROUBLESHOOTING

7

The HiWatt Ballast is designed for industrial use, and if configured correctly, little or no difficulties should be encountered during its setup or operation. If however, problems do occur, the following checklist may help to isolate the cause and suggest a solution.

Problem	Probable Cause	Solution
Ballast does not turn on at all. (see next problem description for similar symptom)	Ballast run switch turned off, AC power turned off at facility breaker panel or cabinet disconnect switch, ballast or internal fuse failure.	Turn on ballast run switch, turn on facility breaker and cabinet disconnect switch, return ballast to Uvitron for repair if required.
At power on, ballast diagnostic LED flashes and fan pulses but ballast does not turn on.	AC input voltage too low for currently programmed voltage range.	Increase AC input voltage to currently programmed setting to turn unit on, then re-program to lower level if desired using PC interface program, and re-cycle AC power.
Lamp does not light.	Insufficient cooldown time after lamp recently turned off, alarm condition detected, insufficient high voltage isolation between lamp connections/chassis, or lamp at end of life.	Using PC interface program, increase lamp cooldown time or decrease lamp cooldown temp as required, check ballast diagnostic LED flash code (see table 6.10) or use PC interface program to view active alarms and take appropriate action, verify appropriate spacing/insulation between lamp conductors and from conductors to chassis, replace lamp if excessively aged or defective.
Lamp warm-up too long, lamp extinguishes during warm-up or Lamp Ready signal does not assert.	Lamp current limit, lamp rated power or BusV overhead setting too low, rated lamp voltage setting too high or lamp being over-cooled.	Using PC interface program, increase lamp current limit and rated power settings to match ratings of lamp, increase BusV overhead setting to 150V minimum, decrease rated lamp voltage setting to match lamp full power voltage rating. Insure lamp airflow is not too high or lamp temperature setpoint too low.
Lamp flickers or extinguishes at low or standby power.	Standby power setting too low, or lamp being over-cooled at low power.	Increase the standby power level using PC interface program, or decrease lamp airflow at low power. Airflow regulation using damper or VFD may be required.

TROUBLESHOOTING (CONTINUED)

7

Problem	Probable Cause	Solution
Lamp intensity does not change properly according to dimming signal.	Incorrect intensity input select or intensity control parameters settings.	Using PC interface program, verify intensity input type (0-10V, PWM or speed wheel) and intensity params (see sects. 6.2-6.4).
Lamp operates but has low output, or slow curing.	Lamp power or exposure time too low, lamp too far from substrate being cured, defective or excessively aged lamp, reflector or filter glass requires cleaning, filter attenuating UVB, adhesive/coating/ink not compatible with lamp type.	Increase lamp power up to full power, increase product exposure time and retest, adjust lamp height closer to surface being cured, replace lamp, clean reflector and glass, remove filter glass for increased UVB output, compare the adhesive/coating/ink light spectral requirements with the lamp output spectral chart (call factory for optional lamp types if required).
No communication from PC via Ballast USB port.	RS485 active, or PC USB port stalled or allocated, or incorrect ballast Modbus ID.	Ballast USB port is deactivated while RS485 is running, re-plug USB cable to restart port, or verify PC interface program Host ID setting matches ballast Modbus ID.
No communication from PC via Ballast RS485 port.	Incorrect PC serial port selected in interface program, PC port allocated by another device or disabled in computer BIOS, incorrect or duplicate ballast Modbus ID, improper RS485 wiring.	Match port selection to port used or move cable to appropriate/available PC port (check Windows Device Manager for available ports and status), verify PC interface program Host ID setting matches ballast Modbus ID and that if more than one ballast is connected that each has a unique Modbus ID, re-wire RS485 connections appropriately (see table in section 5.5).
Lamp turns off and lamp cool down begins unexpectedly, ballast alarm signal activated.	Ballast has detected fault condition and shut down the lamp.	Check ballast diagnostic LED flash code (see table 6.11) or use PC interface program to view active alarms and take appropriate action.
Alarm due to “No comm HMI to sec, shut lamp and report” (loss of serial communication between HMI computer and ballast secondary side microcontroller).	Remote control of ballast interrupted due to loss of communication with PC. This can be due to serial cable problem, control program stopped, or electrical interference.	When the lamp is enabled via serial port and communication is lost, ballast will alarm and shut off because user will not be able to shut down. Check serial port cabling and verify control program operating, verify proper routing and shielding of serial port cabling to avoid electrical interference.

TROUBLESHOOTING (CONTINUED)**7**

Problem	Probable Cause	Solution
Alarm due to "Lamp extinguished after warm-up complete".	BusV overhead too low, lamp power too low, lamp over-cooled, lamp disconnected or lamp failure.	Using PC interface program, increase BusV overhead setting to 150V min, increase lamp power to maintain min temperature, insure lamp airflow is not too high or lamp temperature setpoint too low, check lamp cabling or replace lamp.
Alarm due to lamp or ballast over-temperature warning or fault.	Lamp temp setpoint too low, lamp power too high, lamp or ballast cooling airflow too low, ambient too hot.	Refer to temp limits in sect. 6.11, adjust lamp temp setpoint accordingly. Verify appropriate lamp or ballast airflow and check for excessive ambient temp. Check any filters for restrictions.
Alarm due to "Lamp cassette over-temp switch activated".	Over temperature thermal switch in lamp housing activated, or associated wires open.	Open lamp thermal switch signal will cause alarm and lamp shutdown. Check for proper lamp temp/airflow, and verify lamp power setting with PC interface program.
Alarm due to "Lamp cassette not locked or not installed" (system safety interlock signal open).	Lamp cassette open, system safety guard open or E-stop switch activated, or associated safety interlock signal disconnected.	Open safety interlock signal will cause alarm and lamp shutdown. Check all system safety interlock switches or other causes of break in Interlock signal loop between pin 11 and 24V return of ballast DB25 connector.
Alarm due to "Loss of "blower ON" feedback signal".	Lamp blower contactor or variable freq. drive (VFD) off, or associated status signal line open.	If status signal from blower contactor or VFD opens, alarm will occur and shut down lamp. Check contactor or VFD for fault, or open signal between pin 3 and pin 5 of ballast 9 pin DSUB connector.
Lamp power and intensity drop below the full power set values as lamp ages, possibly causing longer cure time.	Lamp voltage typically drops as the lamp ages and requires higher current to maintain constant power output.	Using PC interface program, verify that the lamp current limit setting is 10% higher than rated lamp current in order to allow lamp current to increase as the lamp ages. Increase the current limit if required.

For troubleshooting assistance for all other problem types or alarm conditions not listed here, contact Uvitron International technical support:

Phone: (413) 731-7835
 Email: info@uvitron.com

REPLACEMENT PARTS AND ACCESSORIES**8****8.1 Ordering Information**

To order replacement parts or accessories, or to obtain further information, please contact Uvitron Customer Service:

Uvitron International, Inc.
171 Doty Circle
West Springfield, MA, USA 01089

Tel. (413) 731-7835
Fax (413) 731-7767
Web site: www.uvitron.com
Email: info@uvitron.com

8.2 Replacement Parts & Accessories List

Item	Part Number
<i>HiWatt</i> electronic UV arc lamp ballast, Mid Power	UV00001192
<i>HiWatt</i> electronic UV arc lamp ballast, High Power	UV00001807
<i>HiWatt</i> Interface Configuration Software CD ROM	UV00001809
Touch Screen Panel PC, 1GB Ram, 160GB HDD, Win XP Embed	UV00001825
<i>HiWatt</i> Interface Touch Screen Software CD ROM, 8 ballast	UV00001810
<i>HiWatt</i> Ballast instruction manual	UV00001826
Lamp output 3 position pluggable terminal block	UV00001557
AC power input 5 position pluggable terminal block	UV00001558
DB9 female control signal terminal block for field termination	UV00001597
DB25 female control signal terminal block for field termination	UV00001598
DB9 control signal terminal block gender changer, male / male	UV00001595
DB25 control signal terminal block gender changer, male / male	UV00001596
Airflow damper w/ actuator, lamp temperature regulator, 6" dia.	UV00002260
Thermistor, 4" long, 3/16" Dia., 10K ohms, lamp temperature	UV00001678
Thermistor compression fitting, L=1.81", 3/16" dia, 1/4" male NPT	UV00001679

TECHNICAL SPECIFICATIONS**9**

Category	Parameter	Value	Conditions/Notes
General	Model	HiWatt Arc Lamp Ballast	
	Part Number	UV1192 (mid-power)	UV1807 (high-power)
	Input Voltage	208/240/480VAC 60Hz, 200/230/380/415VAC 50Hz 1Φ or 3 Φ, programmable via serial port	
	Source Input Frequency	47 Hz to 63 Hz	
	Input Current	30 Amps maximum	See charts below
	Efficiency (Typical)	92 - 96%, lamp type & input voltage dependent	
	Connectors	Pluggable terminal blocks for input & lamp, 9 & 25 pin DSUB for low voltage & control	
	Controls and Indicators	Run/Stop switch, bicolor flashing diagnostic LED	
	Fan / Auxiliary Outputs	3.3V@ 0.5A, 24V@ 1A	DC Voltages
	Protection	Inrush current prevention Line voltage surge Short circuit, all outputs: Lamp 3.3V and 24V Open circuit, limited to 1100V RMS Hot re-strike, Over temperature	
Lamp Section	Lamp Type	Mercury vapor/ metal halide, medium pressure	
	Output Voltage	200 to 850 VRMS	Programmable
	Output Current	Up to 17A RMS max	See power curves below
	Wave Shape (Current / Voltage)	40 to 200 Hz AC square wave	Programmable
	Power Regulation:	± 2%	Line and lamp
	Operation:	Continuous mode	
	Lamp Igniter:	Integrated, time limited repetitive strike	
Environmental	Operating Temperature	+10 °C to +40 °C (+50 °F to +104 °F)	
	Storage Temperature	0 °C to +60 °C (+32 °F to +140 °F)	
	Relative Humidity	30 to 75% operating, 10 to 100% storage	Non-condensing
	Cooling	Forced air	Internal dual fan
	Integrated 3Φ EMI filter		
Packaging	Housing:	Enclosed sheet metal	Panel front/rear mountable
	L x W x H (inches)	20.11" x 8.32" x 4.54"	See overall dims, drawing
	Weight (lbs.)	25 (UV1192)	35 (UV1807)

TECHNICAL SPECIFICATIONS (CONTINUED)

9.2 Ballast 3 Phase AC Input Current vs. Lamp Voltage & Current

The following charts can be used to predict required AC input current based on desired AC input voltage, and on the selected lamp's voltage and current requirements. Select the chart that corresponds to the desired AC input voltage and number of input phases, then find the input current curve that comes closest to the intersection point of the "X" axis lamp voltage and "Y" axis lamp current. Note that HiWatt ballast models are limited to the following maximum input current ratings as follows:

HiWatt Model #	Max Input Current
UV1192	10.5A
UV1807	15.0A

Maximum lamp voltage is limited by the selected 3 phase AC input voltage level as follows:

AC Input Voltage	Max Lamp Voltage
200	340
208	370
230	413
240	438
380	781
415	850
480	850

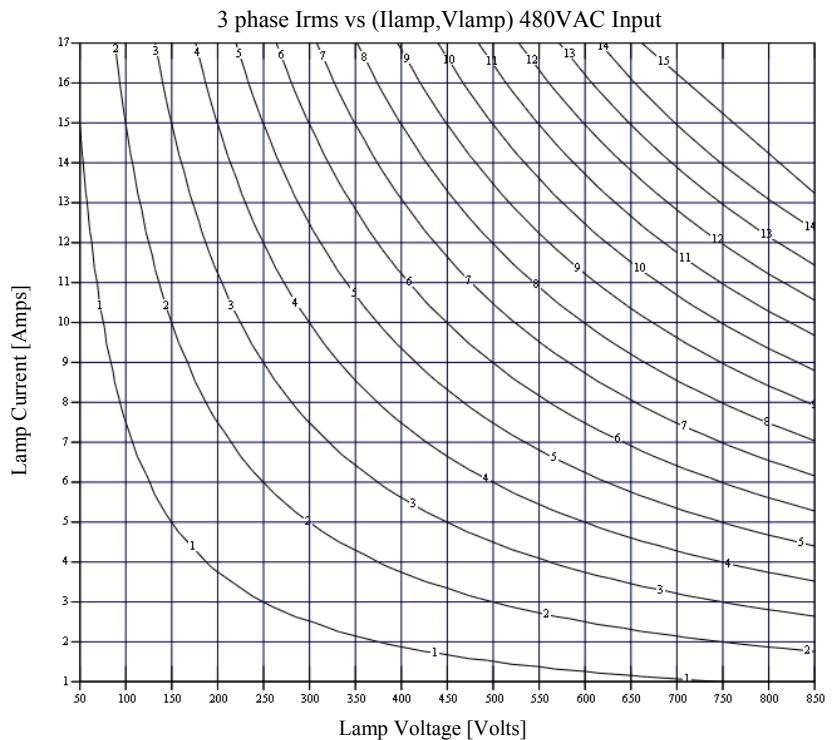
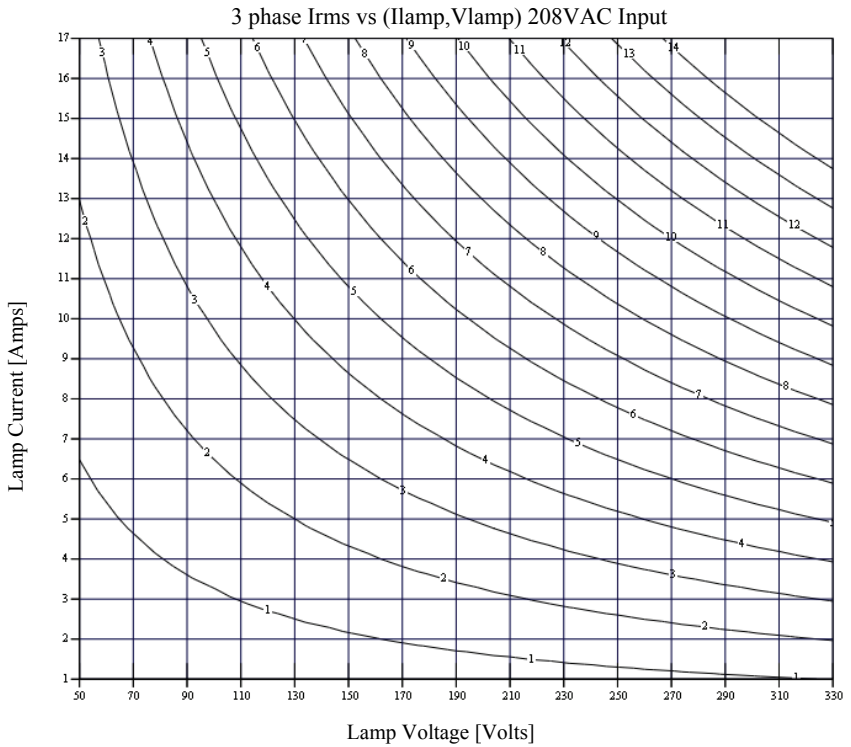

TECHNICAL SPECIFICATIONS (CONTINUED)

Ballast 3 Phase AC Input Current vs. Lamp Voltage & Current (Continued)

NOTE: If your lamp's parameters are not within the ranges shown in the charts, contact Uvitron International customer service for an alternative lamp to meet your requirements.

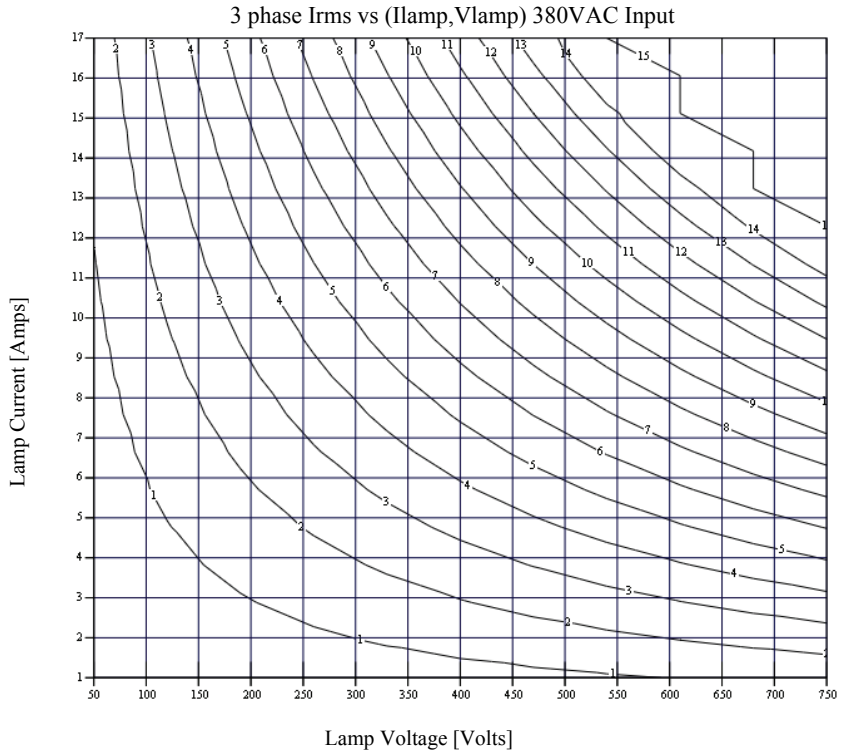
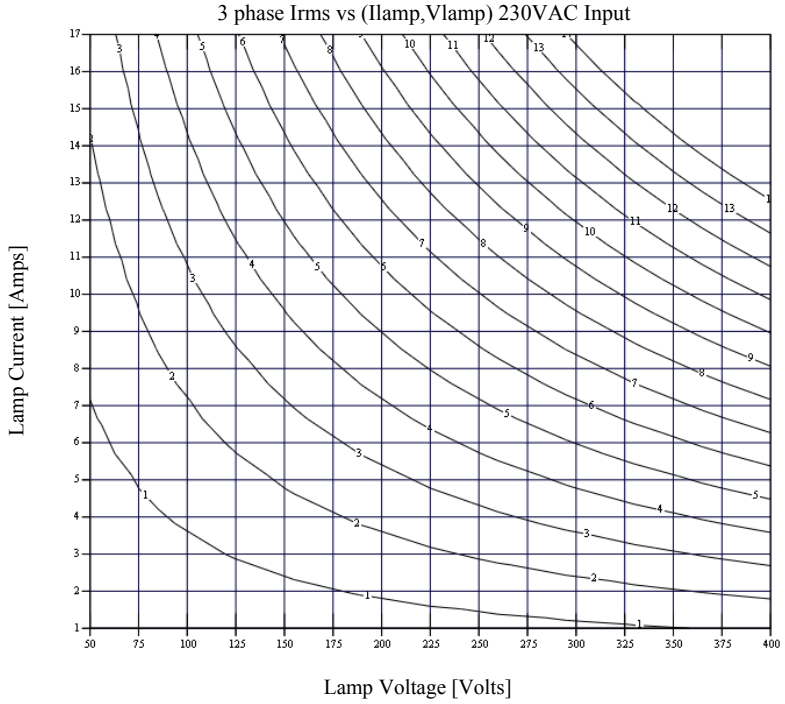

TECHNICAL SPECIFICATIONS (CONTINUED)

9.3 Ballast Single Phase AC Input Current vs. Lamp Voltage & Current

Maximum lamp voltage is limited by the selected single phase AC input voltage level as follows:

AC Input Voltage	Max Lamp Voltage
200	416
208	438
230	501
240	529
380	850
415	850
480	850

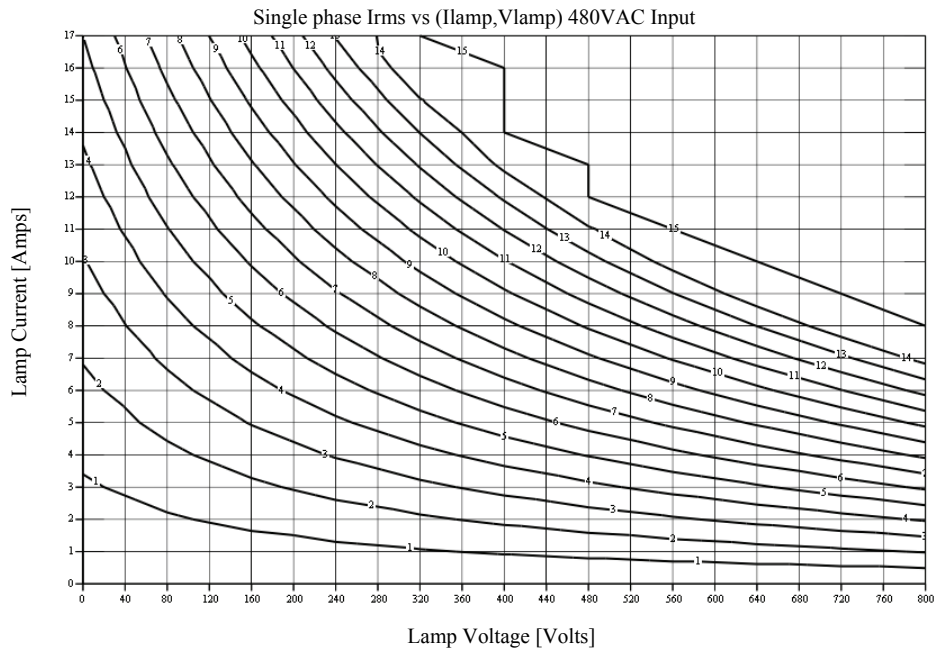
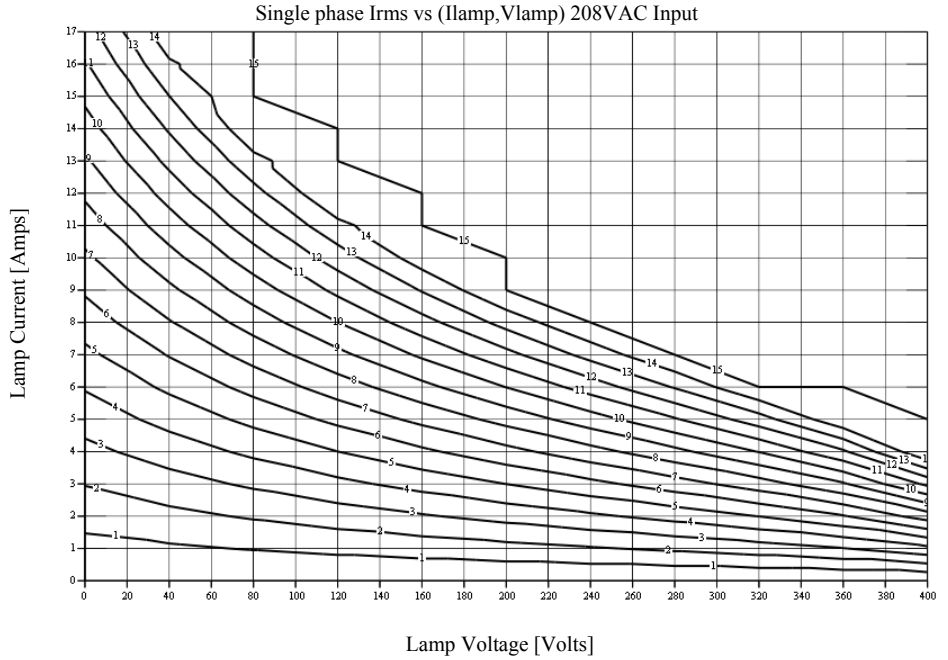

TECHNICAL SPECIFICATIONS (CONTINUED)

Ballast Single Phase AC Input Current vs. Lamp Voltage & Current (Continued)

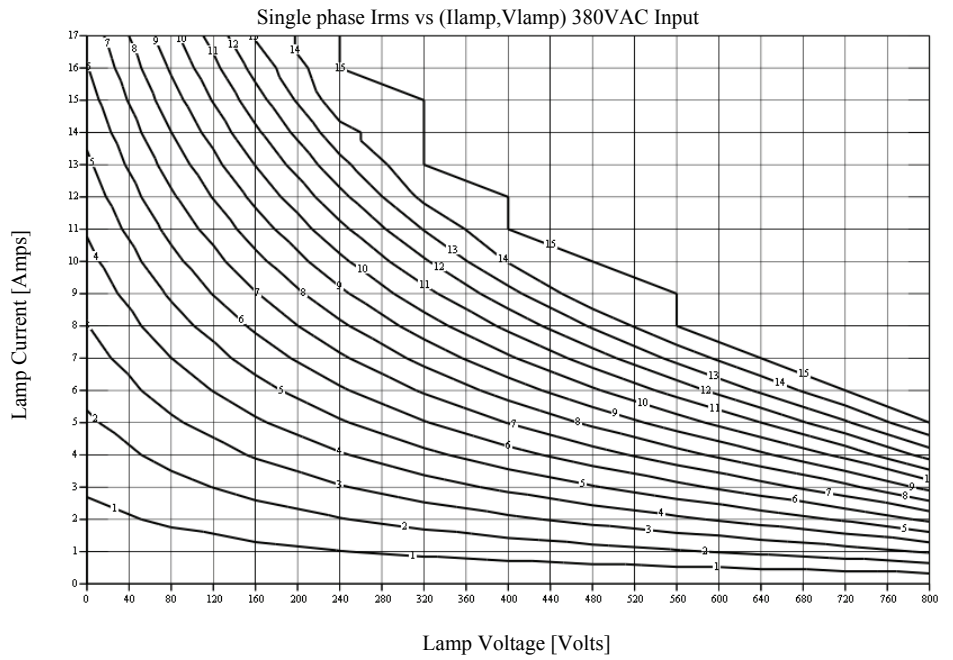
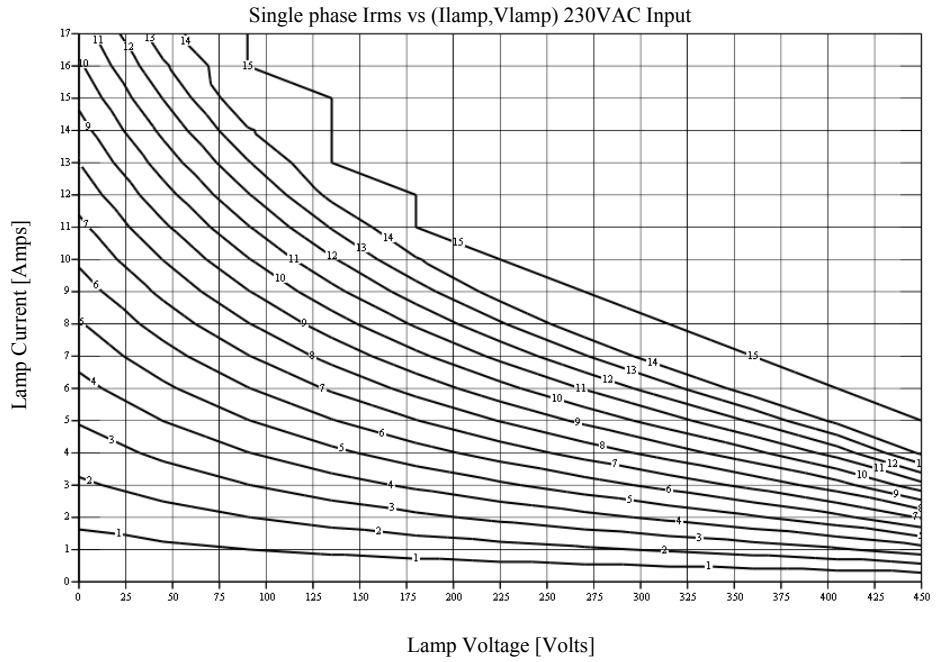

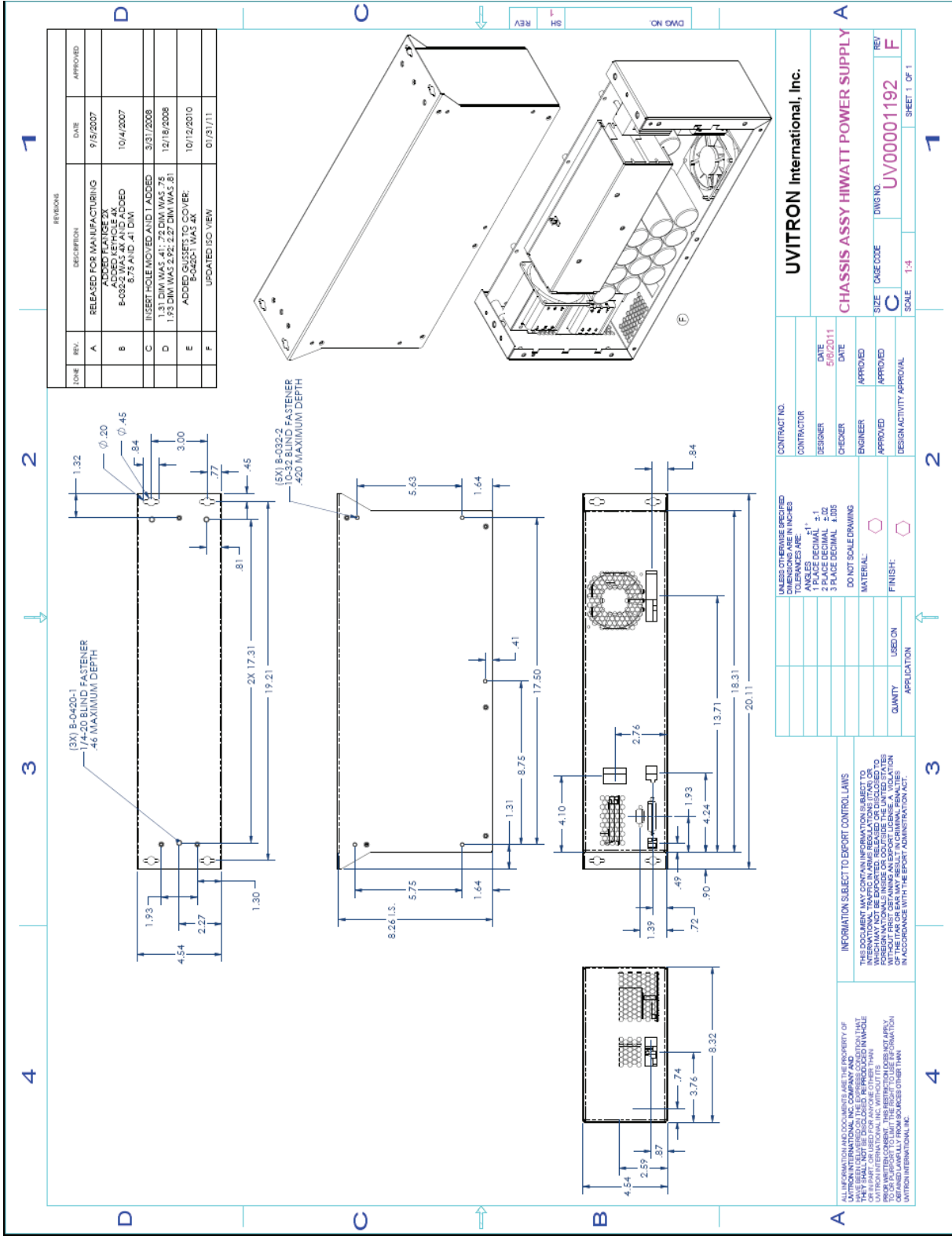

Fig. 9, HiWatt overall dimensions and Mounting hole locations

WARRANTY INFORMATION

10

UVITRON INTERNATIONAL WARRANTY

UVITRON International, Inc. warrants its products against defective material and workmanship under normal use for a period of 1 (one) year from the date of shipment to our customer. This warranty does not apply to any product that has been subjected to misuse, accident, improper installation, improper application or improper operation, nor does it apply to any product that has been repaired or altered by other than a factory authorized representative. Any tamper-proof seals that are broken will void the warranty. There are no warranties that extend beyond those herein specifically stated.

SERVICING POLICY

WARRANTY REPAIR

All products will be repaired at the factory or replaced at no charge throughout the warranty period. If a unit is returned for an approved repair, the warranty will be extended for the length of time required to complete the repair or to replace the unit.

OUT OF WARRANTY REPAIR

Products requiring repair that are beyond the warranty period, will be subject to a fee depending on the degree of repairs. Please consult the factory for details.

SERVICE WARRANTY

UVITRON International, Inc. warrants all repair work for a period of 1 (one) year from date of repair. This warranty applies only to the repair for which the unit was returned.

RETURN MATERIALS AUTHORIZATION

A Return Material Authorization (RMA) number must be obtained so that we may process your returned equipment. Please call the factory service department to obtain a RMA Number.

SHIPPING INSTRUCTIONS

Products that are shipped to the factory for repair will be shipped at the customer's expense, and will be returned to the customer at no charge by UVITRON International, Inc., via normal shipping method for said product. Products that are shipped to the factory on a freight collect basis will not be accepted.